

FUSION™

A Marine Fuel Accountability & Management System

Description

The FUSION™ system is an advanced purpose-built Marine Vessel Fuel Accountability and Management System that provides a means to accurately measure, record, report and display the fuel consumption and fuel efficiency of marine vessel diesel engines. The system accepts an input from an existing GPS serial data output (NMEA 0183) allowing the vessel crew to select the optimum throttle position based on the real-time display of fuel efficiency.

FUSION™ is designed to measure the fuel consumption of propulsion engines, with an option to measure the fuel consumption of generator engines. The system is configurable for mechanical and electrical drive propulsion systems, and fixed or controllable pitch propellers. As such FUSION™ can be configured to monitor the effects of engine RPM, controllable pitch propeller angle, generator power, and/or drive shaft torque on the fuel efficiency of a vessel.

A typical FUSION™ system consists of temperature compensated fuel supply and fuel return flow meters for the main propulsion engines, RPM sensors, one engine room junction box to tie all engine room sensors to a central location, one wheelhouse Data Acquisition Unit with a dimmable, touch screen display, one system power supply, and one set of armored cable for all system component interconnections. The fuel supply and fuel return flow meters are a "fail open" design, allowing full fuel flow in the unlikely event of a meter lockup.

A comprehensive software analysis package is available for FUSION™ that allows an operator to analyze consumption records and truly measure the effectiveness of fuel saving strategies. The data records can also be used for scheduling maintenance, recording emissions statistics, creating ISO 14000 records, including fuel consumption records in mission planning and/or customer billing, and audit support.

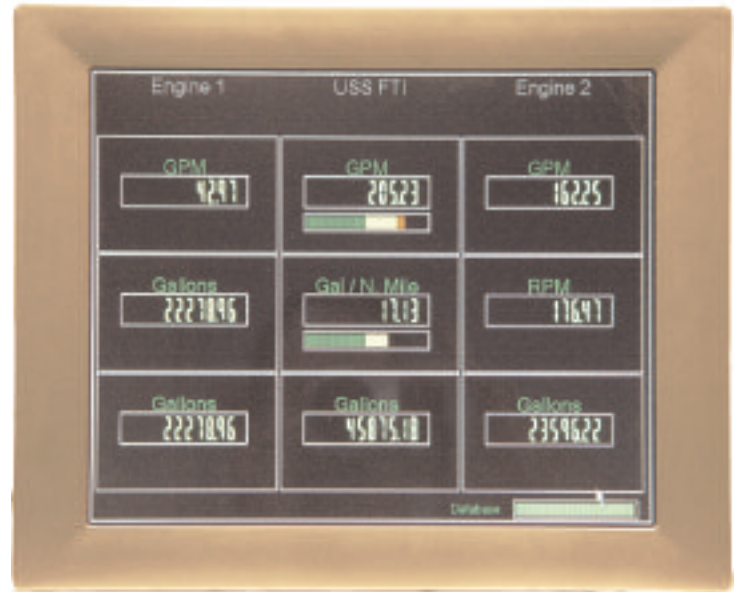

FUSION™ Wheelhouse Data Acquisition Unit

Features

- Designed specifically for the professional marine operator
- Customizable configuration for each unique vessel
- Real-time wheelhouse display of fuel consumption and efficiency parameters of the user's choice
- Optimized fuel usage for any given weather or sea conditions
- Log of fuel consumption and efficiency data for analysis (daily, weekly, monthly and yearly display available via Fleet Manager software)
- Stainless steel flow meter construction with fail-open geometry for uncompromised vessel safety
- Armored cable interconnections in engine room for highly robust and enduring installation
- Excellent speed of response
- Repeatability of $\pm 0.05\%$
- Temperature compensated fuel flow measurement accuracy better than $\pm 0.5\%$

Applications

The FUSION™ system is designed for use on marine vessels such as oil and gas offshore supply and support workboats, ferries, fishing trawlers, ocean and river tugs, Coast Guard cutters, offshore drilling ships, cruise ships, tankers, and cargo ships. The flow meters are sized for main engines between 1000 HP and 5000 HP each, and diesel generators of 750 kW to 3730 kW. The standard fuels are #2 diesel, MGO, or MDO, but the flow meters can be sized for larger engines and/or calibrated for other fuels upon request.

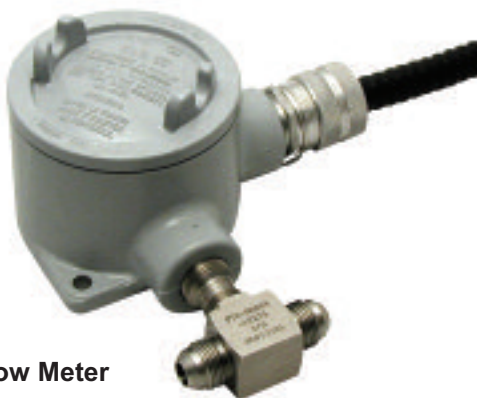

FUSION™ Flow Meter



FUSION™ Wheelhouse DAU



Engine Room Junction Box

Specifications

Materials of Construction

Turbine Flow Meter

Flow Meter Housing	316 SST
Rotor	430F SST
Ball Bearings	440C SST
Pickoff Housing	303 SST
PCB Enclosure	Epoxy-coated Aluminum (NEMA 4X rated)

RPM Sensor

Sensor Housing	303 SST
PCB Enclosure	Epoxy-coated Aluminum (NEMA 4X rated)

Engine Room Junction Box

Enclosure	Fiberglass/Polyester (NEMA 4X rated)
Cable Glands	Aluminum

Interconnection Cable

Cable Wiring	Two twisted shielded pair, 18-gauge stranded plated copper cable
Cable Armor	Aluminum interlock armor
Armor Jacket	PVC

Hardware Description

Turbine Flow Meter

Calibration	10 points over flow meter operating range
Viscosity Range	1.2 to 25 cst
Standard Calibrations	#2 diesel, Marine Gas Oil
End Connections	Male thread per AS4395 (see Flow Meter Options for individual sizes)
Temp. Compensation	RTD integrated in flow meter
Geometry	Turbine provides fuel flow to engine in the event of turbine seizure

Flow Meter Transmitter

Input Power	24 VDC
Signal Output	RS-485
Operating Temperature	-40° to 185° F (-40° to 85° C)
Enclosure	NEMA 4X rated epoxy coated aluminum with cable gland connections for water proof seal

Specifications (cont'd)

Data Acquisition Unit & Display

Processor	400 MHz
Hard Drive	40 GB
RAM	512 MB
Serial Ports	3 RS232, 1 RS 485, 2 USB
GPS Interface	Serial data NMEA 0183
Display	12" color LCD
Sunlight Readable	Transflective display
Dimmable Screen	Yes (dimmer control via software)
Viewing Angle	100°
Human/Computer Interface	Touch screen
Mounting Configuration	Panel or bracket mount
Operating Temperature	32° to 122° F (0° to 50° C)

Power Supply

Power Input	115 VAC +20%/-25%, 50/60 Hz
Overload Protection	UPS shutdown if overload exceeds 105% at 20 sec., 120% at 10 sec., 130% at 3 sec.
Battery Type	Sealed, maintenance-free lead acid
Transfer Time	4 milliseconds
Backup Time	15 – 25 minutes
Recharge Time	4 hours
Power Supply	115 VAC input to 24 VDC output
Terminal Strip	Din rail mount
Operating Temperature	32° to 104° F (0° to 40° C)

Main Engine RPM Sensor

Sensor Thread	5/8" – 18 UNF-2A
Thread Length	2"
Signal Output	RS 485
Operating Temperature	-40° to 221° F (-40° to 105° C)
Enclosure	NEMA 4X rated epoxy coated aluminum with cable gland connections for water proof seal

Analog Sensor Input Module

Channels	8 independently configurable
Input Impedance	Voltage: 20 Mega Ohms Current: 120 Ohms
Inputs	4-20 mA, 0-5 V, 0-10 V
Operating Temperature	14° to 158° F (-10° to 70° C)
Enclosure	Junction box with 4 cable gland input connections, 1 cable gland output

System Specifications

Operating Temperature Range

Standard Engine Room ⁽¹⁾	-40° to 185° F (-40° to 85° C)
Complex Engine Room ⁽²⁾	14° to 158° F (-10° to 70° C)
Wheelhouse	32° to 104° F (0° to 40° C)

Filtration Needed 10 Micron

Performance

Calibration Accuracy	±0.05%
Repeatability	±0.05%
Flow Meter Accuracy	±0.10% ⁽³⁾
Viscosity Coefficient	±0.016%/cst

Flow Meter Capacity

Flow Meter	Minimum Flow (GPH)	Maximum Flow (GPH)	End Connection ⁽⁴⁾
FT4-8AEU3-LEAT5	12	180	-8
FT6-8AEU3-LEAT5	30	300	-8
FT8-8AEU3-LEAT5	45	480	-8
FT-08AEU3-LEAT5	60	600	-8
FT-10AEU3-LEAT5	75	900	-10
FT-12AEU3-LEAT5	120	1500	-12

Notes:

- 1) A standard engine room monitors only engine RPM and engine fuel consumption.
- 2) A complex engine room monitors existing analog signals such as kW, torque, and/or propeller angle.
- 3) At specific calibration viscosity.
- 4) Flow meter end connections are male per AS4395.

FUSION™ Component Part Numbers

Data Acquisition Unit & Display (DAU)

Part Number 11-67965-103
Description 12.1" transfective display with resistive touch screen interface

Controller Software for DAU

Part Number 09-68063-103
Description FUSION system operating software, loaded & configured on DAU

DAU Mounting Bracket

Part Number 39-69209-102
Description Wall mount bracket

Part Number 39-69209-101
Description Ceiling mount bracket

Wheelhouse Power Supply

Part Number 14-67950-101
Description 115 VAC input UPS with 24 Vdc power converter and terminal strip system interconnection

Power Supply Transformer

Part Number 19-69109-101
Description 240 Vac to 115 Vac transformer for 240 Vac vessel power

Engine Room Junction Box

Part Number 74-67951-101
Description NEMA 4X rated interconnection junction box with connections for up to 6 Fusion sensors

Part Number 74-67951-102
Description NEMA 4X rated interconnection junction box with connections for up to 10 Fusion sensors

Main Engine RPM Sensor

Part Number 01-67953-101
Description RPM proximity sensor and transmitter for main engines

Analog Sensor Input Module

Part Number 01-69189-101
Description RS-485 converter for up to 8 analog signals from existing vessel instrumentation

Turbine Flow Meter

Part Number FT4-8AEU3-LEAT5
Description 12-180 GPH range, -8 male AN fittings

Part Number FT6-8AEU3-LEAT5
Description 30-300 GPH range, -8 male AN fittings

Part Number FT8-8AEU3-LEAT5
Description 45-480 GPH range, -8 male AN fittings

Part Number FT-08AEU3-LEAT5
Description 60-600 GPH range, -8 male AN fittings

Part Number FT-10AEU3-LEAT5
Description 75-900 GPH range, -10 male AN fittings

Part Number FT-12AEU3-LEAT5
Description 120-1500 GPH range, -12 male AN fittings

Flow Meter Transmitter

Part Number 01-67952-101
Description RS 485 output transmitter in epoxy coated aluminum enclosure, mounted on meter

Armored Interconnection Cable

Part Number 19-68143-102
Description 250' spool of 18 gauge, two twisted pair cable with aluminum interlock armor for all engine room connections

Non-Armored Interconnection Cable

Part Number 19-68144-104
Description 250' spool of 18 gauge, two twisted pair cable for connection from engine room to wheelhouse

Dimensions

Flow Meter

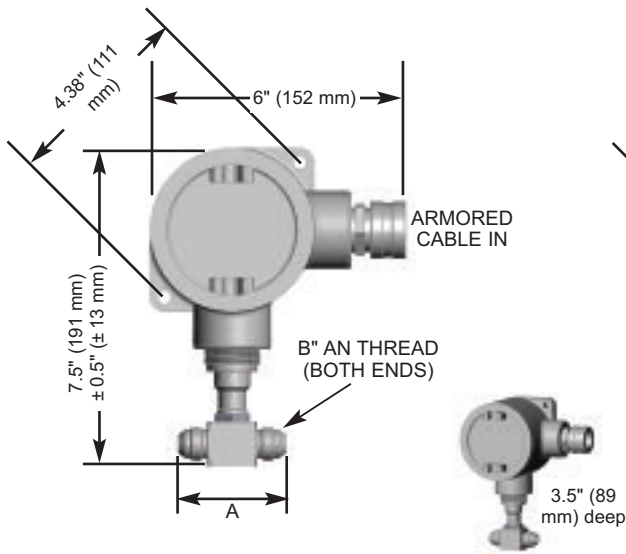

RPM Sensor

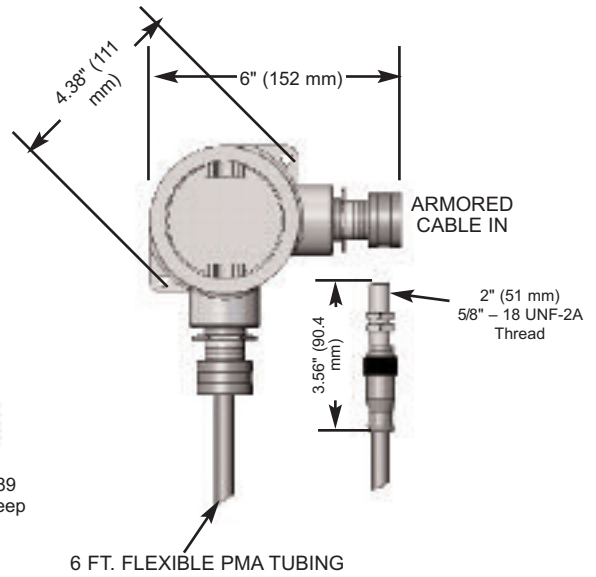

Flow Meter	Dimension A	Thread B
FT4-8AEU3-LEAT5	2.45" (62 mm)	-8
FT6-8AEU3-LEAT5	2.45" (62 mm)	-8
FT8-8AEU3-LEAT5	2.45" (62 mm)	-8
FT-08AEU3-LEAT5	2.45" (62 mm)	-8
FT-10AEU3-LEAT5	2.72" (69 mm)	-10
FT-12AEU3-LEAT5	3.25" (83 mm)	-12

Wheelhouse Display Dimensions

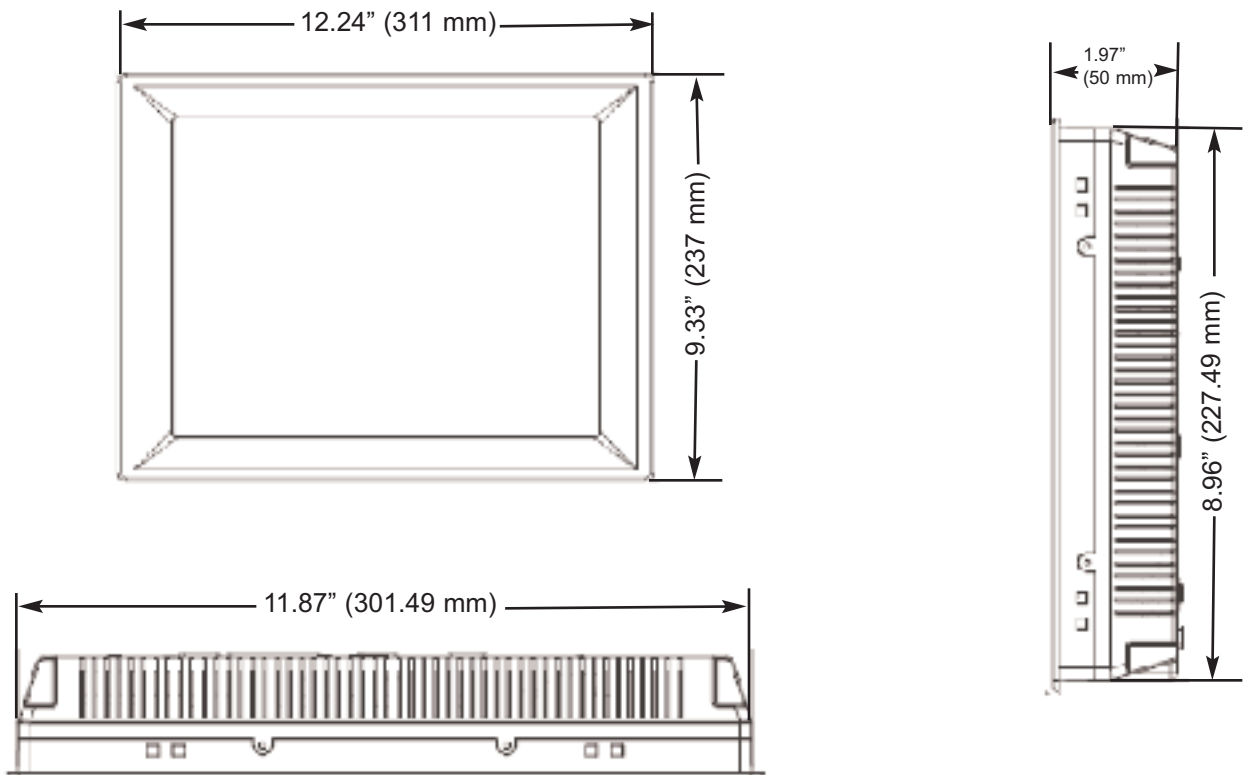

Dimensions (cont'd)

Engine Room Junction Box

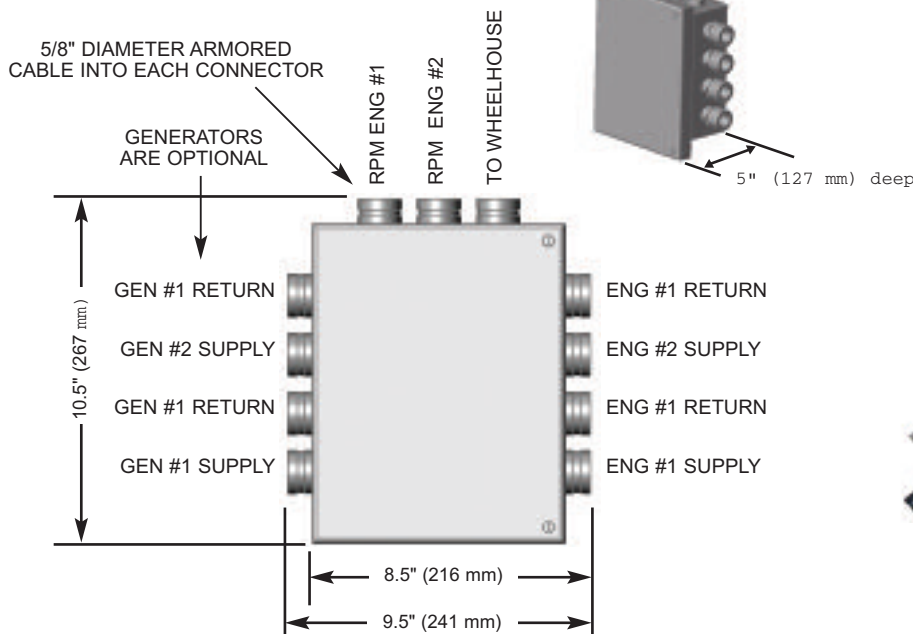

Wheelhouse DC Power Supply

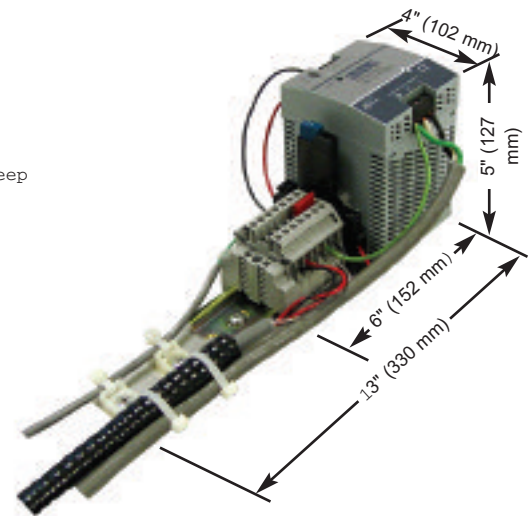

Junction Box Mounting Holes



Mounting hole pattern: feet swivel so there are two options. Mount with 1/4" or 5/16" bolts. Place a washer on the bolt.

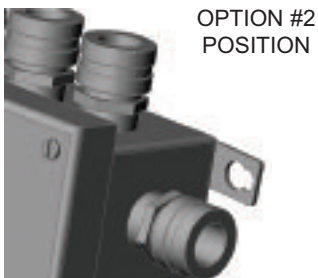
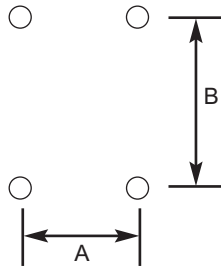

	Dimension A	Dimension B
OPTION #1	5.00" (127 mm)	9.12" (232 mm)
OPTION #2	7.12" (181 mm)	6.90" (175 mm)

UPS



Specifications are for reference only and are subject to change without notice.

Local Representative:



8930 S. Beck Avenue, Suite 107, Tempe, Arizona 85284 USA
 Tel: (480) 240-3400 • Fax: (480) 240-3401 • Toll Free: 1-800-528-4225
 E-mail: ftimarket@ftimeters.com • Web: www.ftimeters.com